

BeDensi B1 Bulk Density Tester

The BeDensi B1 stands as a specialized bulk density tester crafted for assessing the bulk density of samples beyond metal powders. Employing the natural deposition method, it adheres to the standards outlined in GB/T 16913-4.3: Methods of dust character test-Determination of bulk density. Widely utilized in diverse sectors such as food, industrial chemistry, energy battery powder, research institutions, and quality inspection organizations, this tester offers valuable insights into the storage characteristics of powders, particularly within storage containers.

Bulk Density Measurement

GB/T

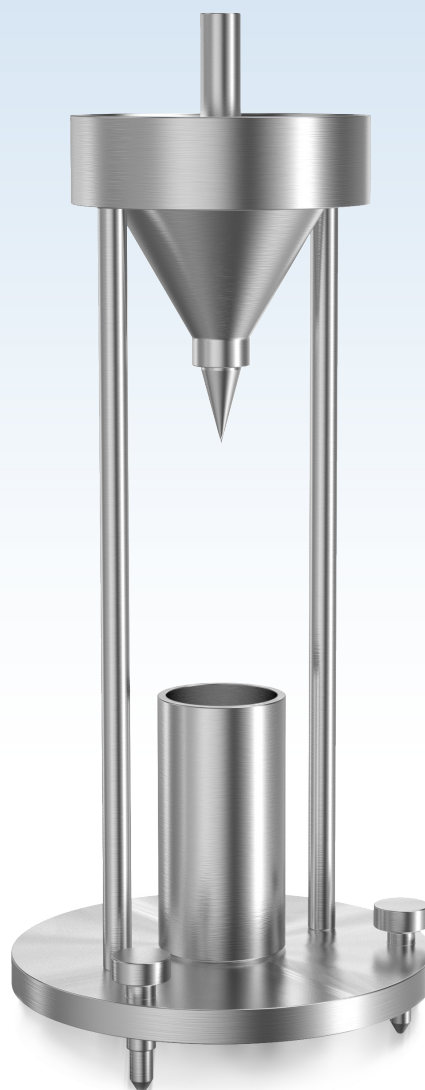

Sample Preparation

The sample powder should be dried at 105°C for 4 hours, followed by natural cooling in the room, and then passed through an 80-mesh standard sieve to remove impurities.

For powders that undergo chemical reactions, melting, or sublimation at temperatures equal to or below 105°C, the drying temperature should be lowered by at least 5°C compared to the temperature at which these reactions occur, and the drying time should be appropriately extended.

Measurement Procedure

Bulk Density

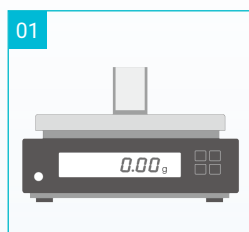

Empty cup and weigh

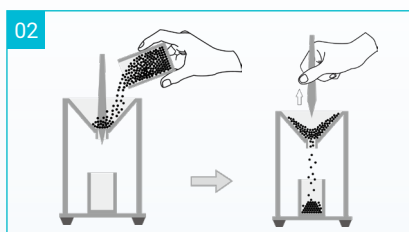

Add sample

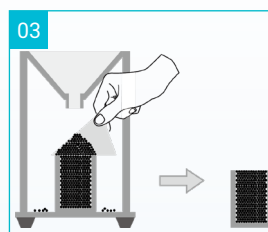

Scrape

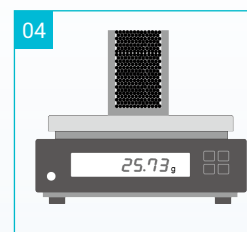

Weigh

$$\text{Bulk Density } (\rho_B) = \frac{M}{V_B} = \frac{\text{Mass (g)}}{25 \text{ cm}^3}$$

where ρ_B is the bulk density, M is mass in grams, and V_B is the bulk volume in milliliters or cubic centimeters.



Result Processing

The same sample should undergo three consecutive tests, and the average of these measurements is taken as the loose bulk density result for that sample. The difference between the maximum and minimum mass values obtained from these three tests should be less than 1 g. If not, additional tests should be conducted until the difference is less than 1 g. The average of three measurements that meet this criterion is then considered as the final determination result.

Application Example

Providing precision in bulk density measurement for different types of coffee samples.

The BeDensi B1 proves to be particularly effective in measuring the bulk density of coarse food powders that may be challenging for other funnel systems. In a comprehensive evaluation, various coffee samples undergo three cycles of measurement. This precision in measurement underscores the instrument's suitability for accurately assessing bulk density in scenarios where coarser powders are involved, providing valuable insights for quality control and process optimization in the food industry.

Sample		Result (g/cm ³)			
		NO.1	NO.2	NO.3	Average
Coarse Grind Coffee		0.3259	0.3224	0.3269	0.3251
Fine Grind Coffee		0.3490	0.3567	0.3501	0.3519
Instant Coffee Powder		0.4090	0.4064	0.4101	0.4085

Specification

Parameter	BeDensi B1
Angle of Funnel	60° ± 0.5°
Orifice Diameter	12.7 mm
Volume of Cup	100 ± 0.5 mL
Internal Diameter of Cup	39 mm
Height between Funnel and Cup	115 ± 2 mm
Compliance (for bulk density)	● GB/T 16913

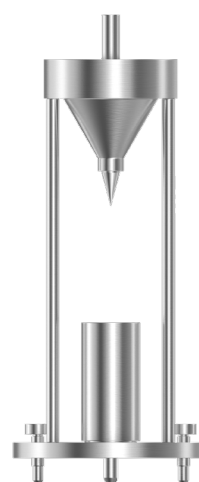

* BeDensi Series is available in the *Bettersize* online store.

Bettersize
BETTER PARTICLE SIZE SOLUTIONS

info@bettersize.com
www.bettersizeinstruments.com

Visit Our BeDensi B1 Site:



RIFERIMENTO PER L'ITALIA



Qi technologies

Qi srl
t +39 06 9105461
www.qitech.it | sales@qitech.it